

电源电压	24 Vdc; (10÷30 Vdc)	Supply voltage	24 Vdc; (10÷30 Vdc)
电流信号输出	4-20 mA (2引脚) (I ≤ 20 mA)	Output signal current	4-20 mA (2pins) (I ≤ 20 mA)
电压信号输出	0÷10 V (3引脚); 最小负载5kΩ (I ≤ 3.5 mA)	Output signal voltage	0÷10 V (3pins); min. load 5kΩ (I ≤ 3.5 mA)
接线保护	防止电源极性反转和输出信号短路	Wiring protection	Against reverse polarity on power supply and short-circuit on output signal
响应时间	≤ 5 ms	Response time	≤ 5 ms
技术	压阻式	Technology	Piezoresistive
稳定性	≤ ±0.25% F.S./年 @ 25°C	Stability	≤ ±0.25% F.S./year @ 25°C
准确度	≤ 0.5% F.S.标准 (0.1%F.S.) @ 25°C	Accuracy	≤ 0.5% F.S. standard (0.1%F.S.) @ 25°C
线性/滞后/可重复性	≤ ±0.5% F.S.	Linearity/Hysteresis/Repeatability	≤ ±0.5% F.S.
工作温度	-25°C至+100°C	Environment temperature	-25°C to +100°C
流体温度	-25°C至+125°C	Fluid temperature	-25°C to +125°C
存储温度	-40°C至+135°C	Storage temperature	-40°C to +135°C
浸润部件材料	本体: AISI 316不锈钢 密封件: 丁腈橡胶	Wetted parts material	Body: AISI 316 stainless steel Seals: NBR
传感器材料	硅胶	Sensor material	Silicone
流体兼容性	油, 水, 水-乙二醇, 用于其他液体 请联系我们技术部门	Fluid compatibility	Oil, air, water, water-glycol; for other fluid please contact our technical office
螺纹连接	G 1/4" 平行	Process thread	G 1/4" parallel
拧紧扭矩	20 Nm	Tightening torque	20 Nm
电气连接和保护等级 (EN 60529)	IP65	Electrical connection and protection degree (EN 60529)	IP65
电磁兼容性 (EMC)	2014/30/EU指令和产品标准 EN 55032:2015. EN55035:2020	Electromagnetic comp. (EMC)	2014/30/UE Directive and EN 55032:2015, EN55035:2020
符合RoHs标准	2011/65/EU (ROHs) 和2012/19/EU指令(WEEE)	RoHs conformity	2011/65/EU (ROHs) and 2012/19/EU Directives (WEEE)

安装和调试 / Installation and commissioning

1. 安装: PTH传感器应尽可能安装在靠近压力测量点的地方, 注意流体流向不湍急。
2. 调试: 根据电气连接图进行布线。在连接和断开换能器连接器之前, 请关闭电源。
3. 处置: 该产品必须按照2011/65/EU (ROHs) 和2012/19/EU (WEEE) 指令, 作为电气/电子废物单独处置。

如何订购 / HOW TO ORDER

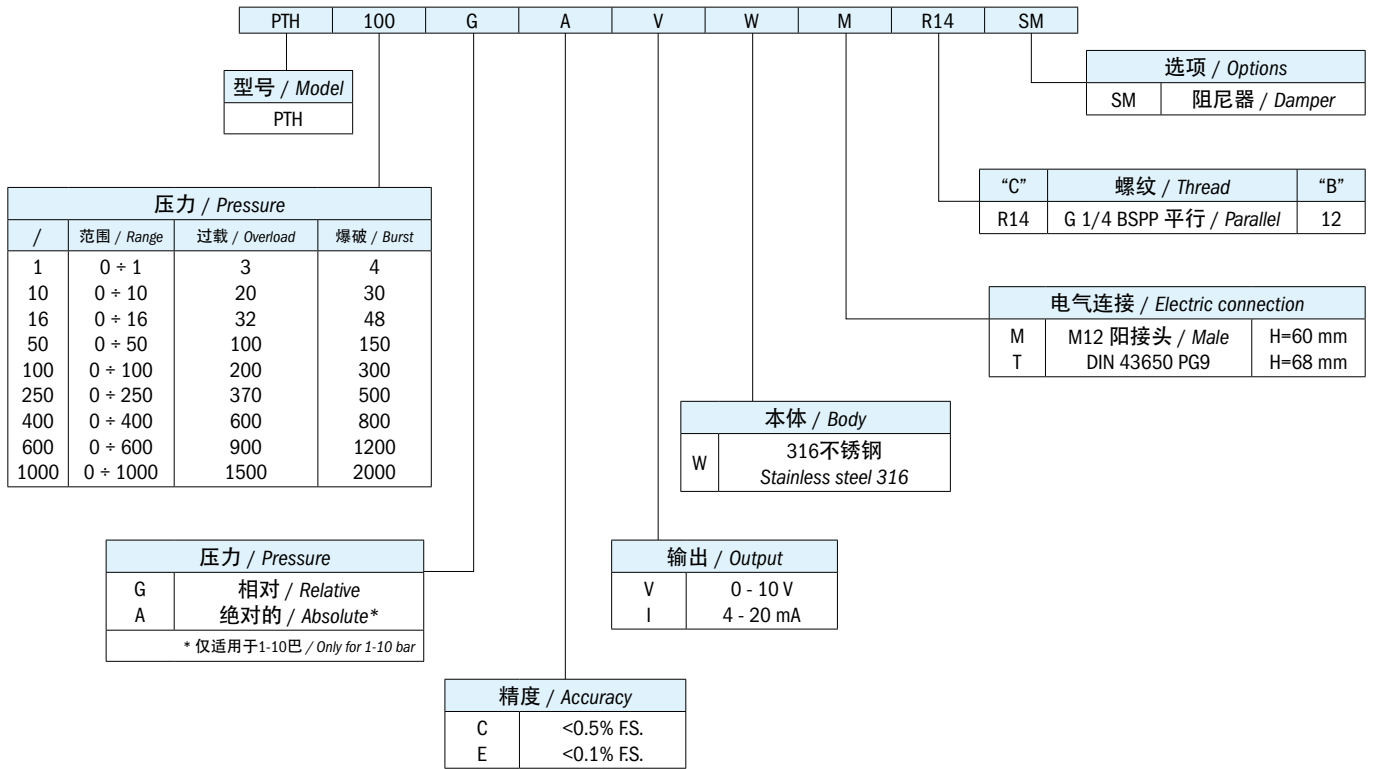

电气连接 / ELECTRICAL CONNECTIONS

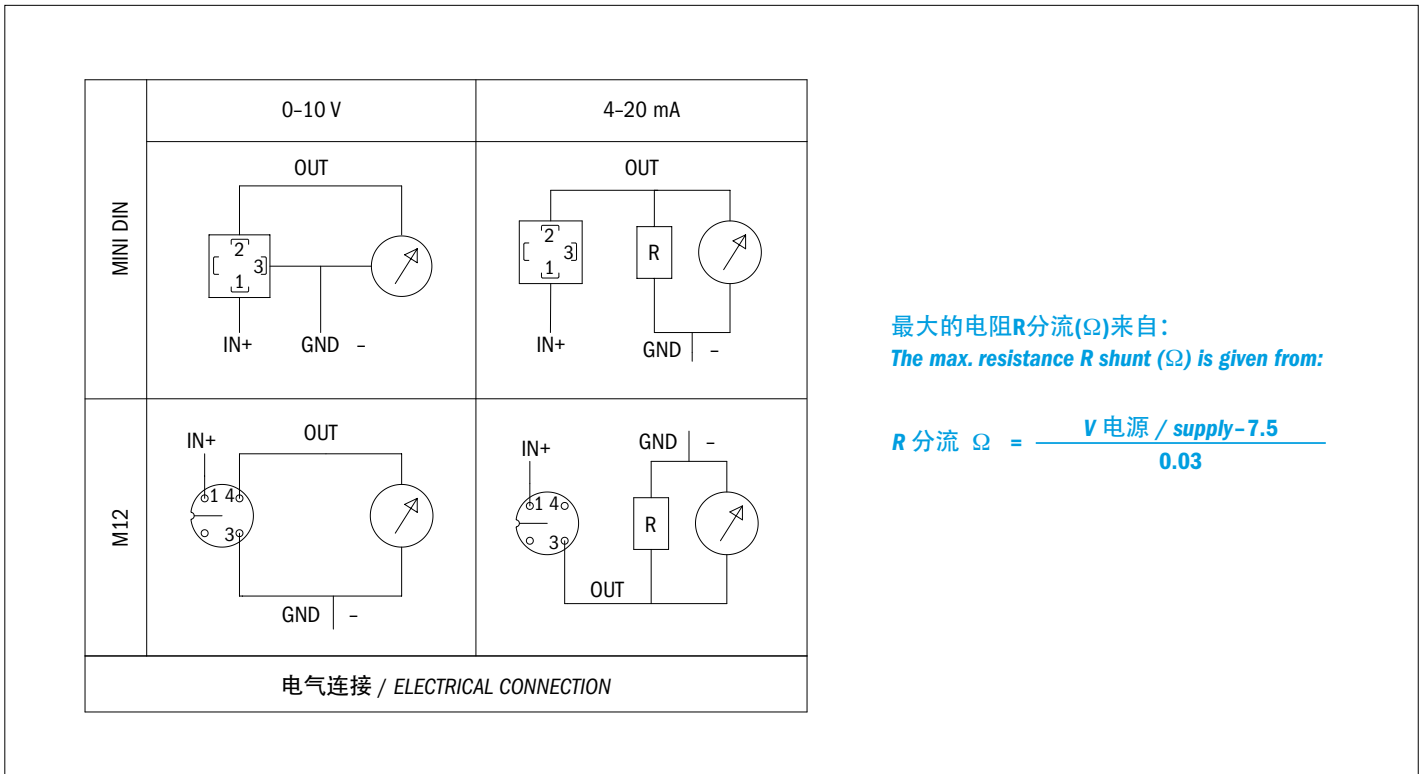

ELETTROTEC保留未经事先通知更改产品技术数据或暂停生产的权利。该压力控制器触点受到强烈冲击或震动时可能会损坏。用户有责任对我们的产品是否适合特定应用进行测试，例如，材料的兼容性测试。仅在现场试验中得到证实的使用才是适当的。该样本中的技术信息基于产品开发过程中的测试和经验值的积累，他们可能并不适用于所有情况。

Elettrotec reserves the right to technical data of change to the products or halt production without prior notice. The pressure controller contacts can be damaged when subject to strong shocks or high vibration. It is the responsibility of the user to test the suitability of our products for the particular application, for example, the verification of material compatibility. The use may only be appropriate if proven in field tests. The technical information in this catalogue are based on tests made during product development and based on empirically gathered values. They may not be applicable in all cases.